

Mini Roller

Assembly instructions and user guide

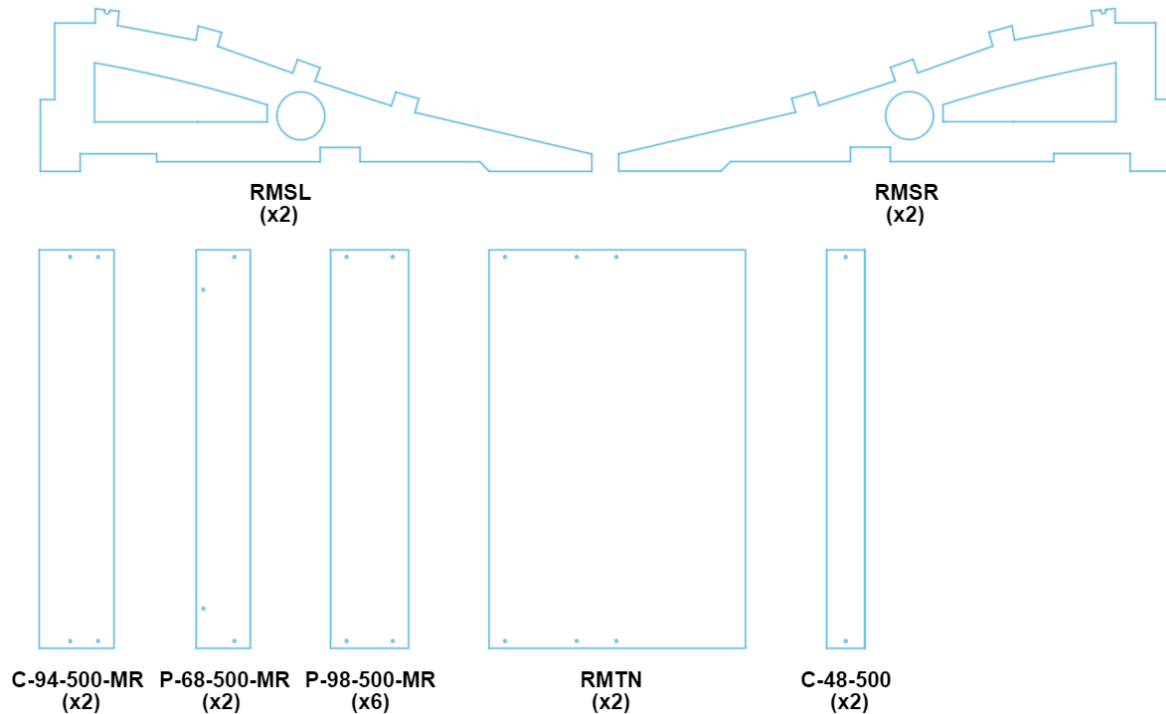

Parts List



50mm flange head screw x 44

50mm countersunk screw x 12

Assembly

Affix the boards to the sides (**RMSL** and **RMSR**) as shown in diagram 1:

P-98-500-MR (x3) – 4 x 50mm flange head screw each

RMTN – 6 x 50mm flange head screw

Affix the cross braces to the sides (**RMSL** and **RMSR**) as shown in diagram 2:

C-94-500-MR – 4 x 50mm countersunk screw

C-48-500 – 2 x 50mm countersunk screw

Affix the board to the sides (**RMSL** and **RMSR**) as shown in diagram 3:

P-68-500-MR – 4 x 50mm flange head screw

Repeat the steps for the other half of the roller. Take care not to overtighten the screws.

Mini Roller

Assembly instructions and user guide



Diagram 1

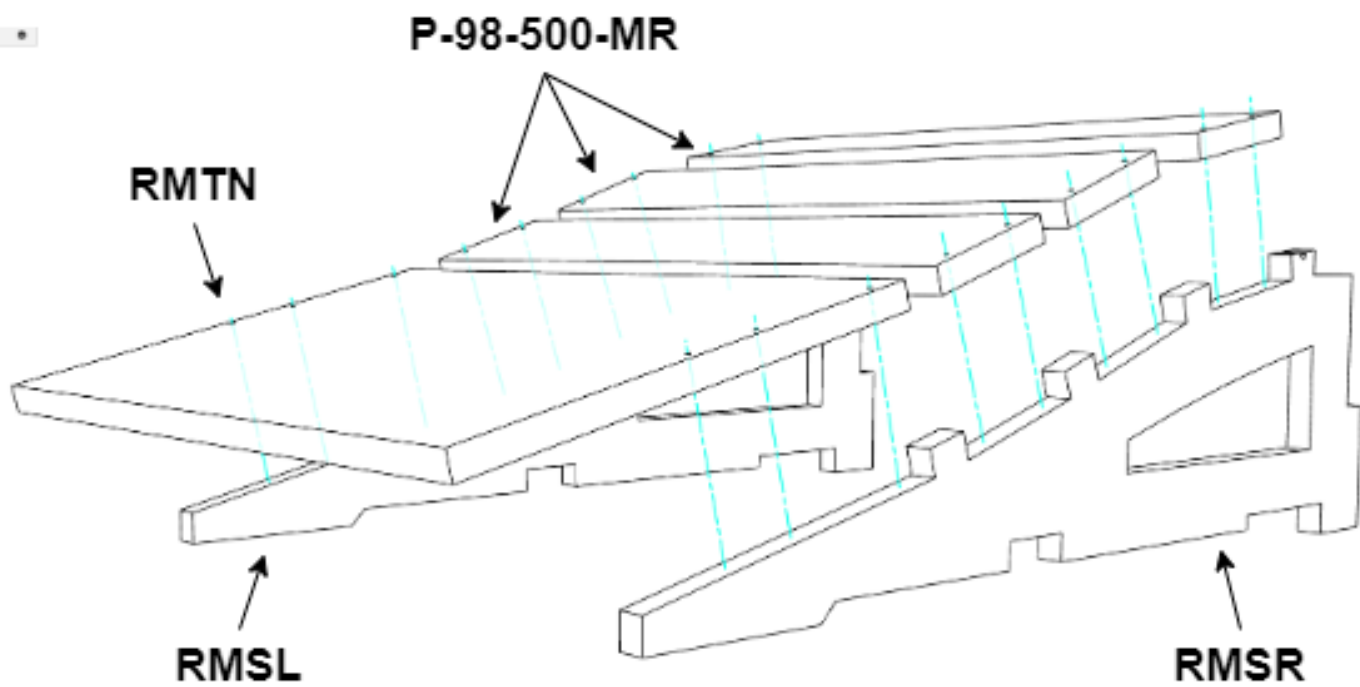

Mini Roller

Assembly instructions and user guide



Diagram 2

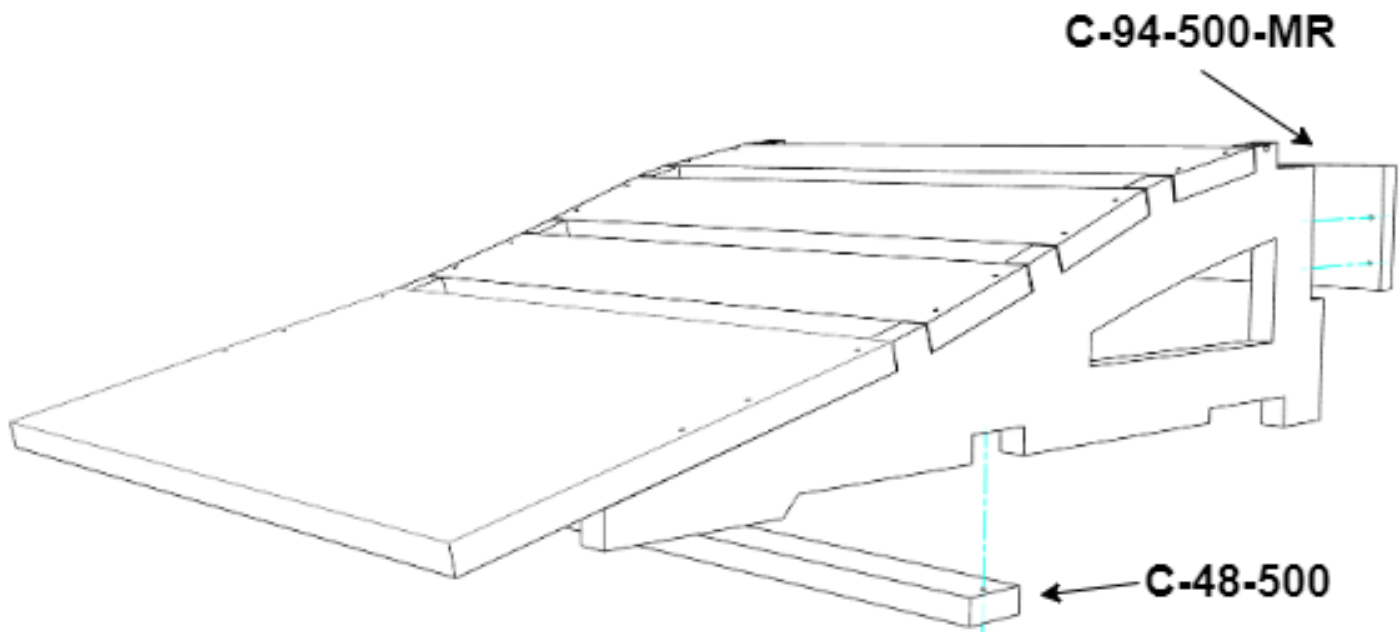

Mini Roller

Assembly instructions and user guide



Diagram 3

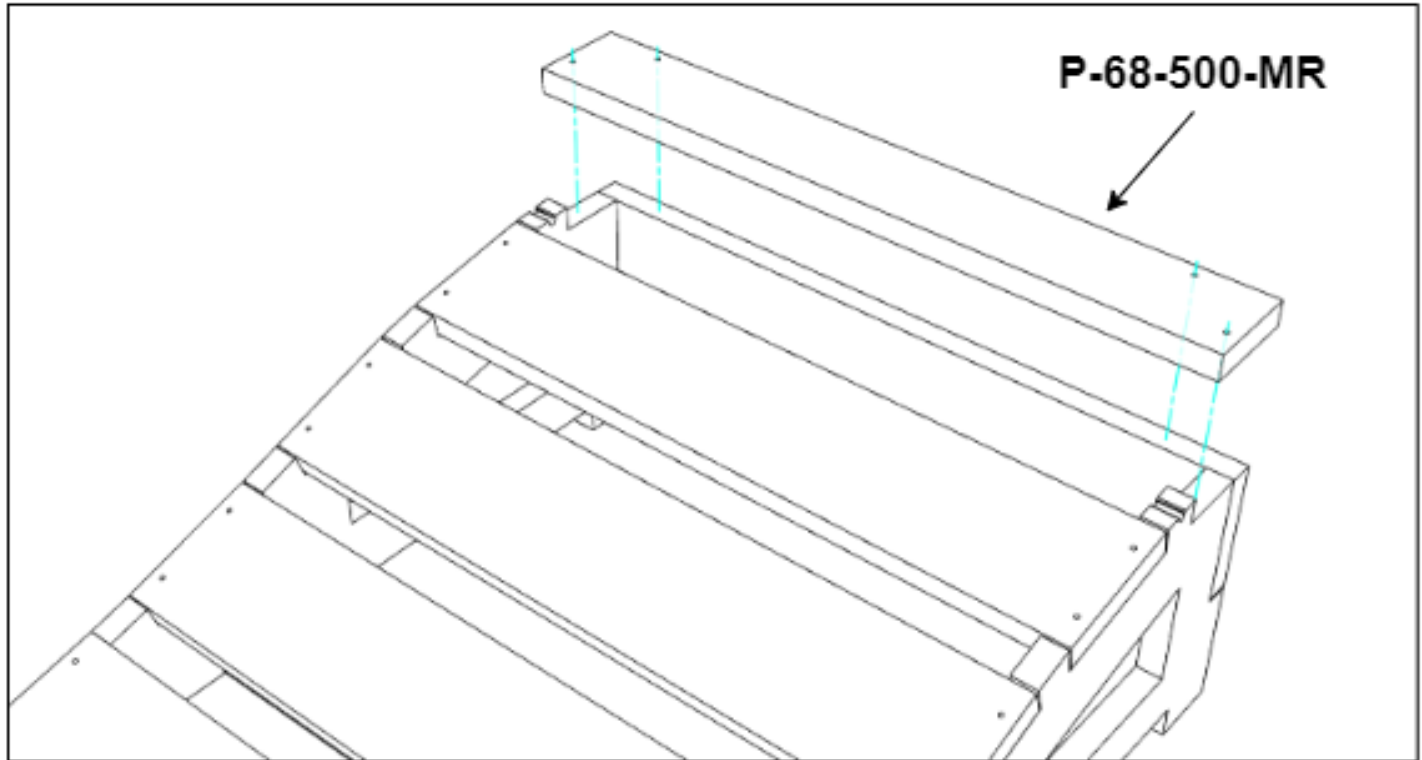

Mini Roller

Assembly instructions and user guide



Usage guidelines

Trail Anywhere products are made from high quality phenolic plywood with a birch core. They are suitable for temporary use in damp conditions but should not be stored outdoors.

- Only use the mini roller on a firm, level surface to ensure stability. Use a connector to prevent the two halves of the roller from separating
- Always use appropriate safety equipment and ensure that your bike is suitable for the type of riding that you are doing
- Inspect the mini roller regularly and stop using it if there are signs of structural damage
- The mini roller has been tested for a maximum combined bike and rider weight of 110kg

We hope you enjoy using your Trail Anywhere mini roller, please have fun and tag **@trailanywhere** in your sends!